

TOE CLIPS & STRAPS

INSTALLATION AND USE

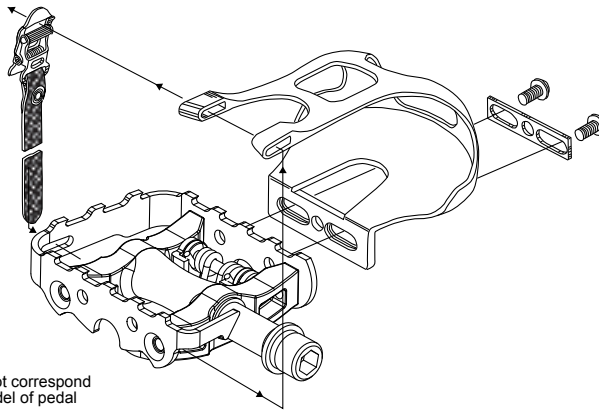

Illustrations may not correspond exactly to your model of pedal

PARTS & TOOLS

PARTS: a. Front cage b. Toe strap c. Two clip d. Bolts **TOOLS:** 6 mm or 8 mm Allen key, (depending on pedal model), 4 mm Allen key

A) ATTACH PEDALS TO CRANKS

Toe clips and straps can be attached to pedals when pedals are on the bicycle, but it is easier to do this job with the pedals removed. 1. Remove pedals: From the inside of the crank, insert 6 mm or 8 mm Allen key into the recess of the axle. The right pedal (marked R) is removed in a counter-clockwise direction. The left pedal (marked L) is removed in a clockwise direction. If axle has wrench flats, you can also use a thin 15 mm wrench to attach pedal. 2. Align the two bolt holes on the bottom of the clip with those on the front cage. With the 4 mm Allen key, screw in the bolts. 3. Before fully tightening, align the clip with the lateral center of the cage, and the inside surface of the clip with the top of the cage. 4. Tighten well, but avoid excessive force. Cage position can be fine-tuned to preference after trial rides.

B) ATTACH TOE STRAPS TO PEDALS AND TOE CLIPS

1. Beginning on the non-axle side of your pedal, thread the toe strap through the horizontal slot in the rear-left of the pedal cage. 2. Continue threading through two slots in the pedal body. Thread most of the strap through until there only about 5 or 6 cm left on the buckle-end of the strap. 3. Thread the strap through slot/s at the top of the toe clip. 4. Join the the two ends of the strap by running the pointed end through the buckle slot with a small roller. 5. Adjust position of strap according to preference. Attach pedal to crank by following instructions elsewhere on this sheet.

C) PEDAL USE WITH TOE CLIPS AND STRAPS

If you have never used toe clips and straps before, take time to learn how to use them safely. When not in use, a toe clip-equipped pedal will hang upside-down. Many pedals have a flip or tab on the rear of the pedal. Use the toe of your shoe on this to flip over the pedal enough to get your foot on the pedal. Make sure straps are loose enough to easily move your shoe in and out. Sit on, or stand over your bike with one foot firmly on the ground. With the other foot, practice getting in and out of the toe clip. When you get used to this, progress to riding slowly in a safe, traffic-free area until engagement and disengagement become natural actions that you can manage easily without looking at your feet. Warning Tight straps are more difficult to disengage from. Loose fitting straps are recommended for beginners and for rides requiring frequent or sudden stops, such as in heavy traffic.