

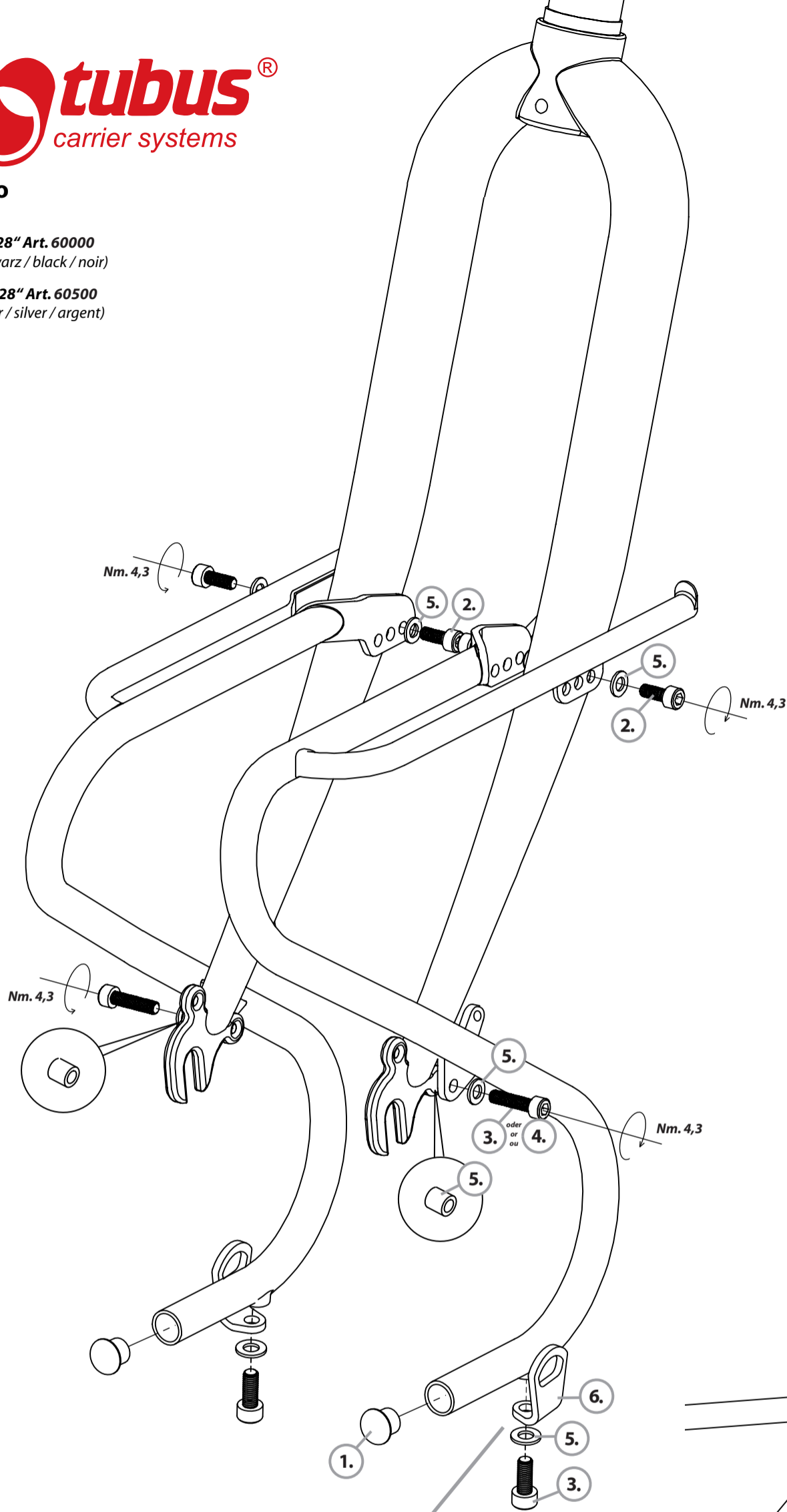









Duo

26" / 28" Art. 60000
(Schwarz / black / noir)

26" / 28" Art. 60500
(Silber / silver / argent)



- | | | | |
|----|-----|---|--|
| 1. | 2 x |  | 14 mm
Art. 72148 |
| 2. | 4 x |  | M5 x 12 mm Inox
Art. 41512 |
| 3. | 2 x |  | M5 x 16 mm Inox
Art. 41516 |
| 4. | 2 x |  | M5 x 20 mm Inox
Art. 41520 |
| 5. | 8 x |  | 5,3 x 12 mm Inox
Art. 40151 |
| 6. | 2 x |  | Taschenöse / for panniers/pour sacoches
Art. 32003 |
| 7. | 2 x |  | 8 x 8 x 5,5 mm
Art. 40300 |
| 8. | 4 x |  | Kratzschutzfolie
Art. 79001 |

- | | |
|---|--|
|  | 4 mm*
Inbusschlüssel / allen wrench /
clé mâle à six pans |
|  | SW8*
Schraubenschlüssel /
combination wrench / clé |

* (Nicht im Lieferumfang enthalten / not included /
n`être pas un élément de la livraison)

für einige Taschen notwendig / for some panniers necessary / pour quelque posches nécessaire
montieren, nur wenn notwendig / mounting only, if necessary / montage seulement si nécessaire



Beachten Sie bitte unbedingt folgende Hinweise,
um Ihre Garantieansprüche nicht zu gefährden.
Please read the following explanation carefully, to
avoid losing your guarantee claim.
Veuillez respecter les indications suivantes pour
ne mettre pas en danger vos droits de garantie.



Kratzschutzfolie / anti-scratch foil / l'emploi des sacoches

Die Kratzschutzfolie ist unbedingt vor dem Gebrauch von Radaschen an den Kontaktstellen aufzukleben. Diese
müssen vorher sauber, öl- und schmutzfrei gemacht werden.

The anti-scratch foil must be glued before using bags onto the area of the carrier-tubes where the pannier-
hooks touch the carrier. The surface of the carrier must be very clean and free of any oil or dirt, before bonding.

Avant l'emploi des sacoches il est important de coller les feuilles protectrices sur les points de contact. La surface
du porte-bagages doit être propre et exempt de toute trace d'huile avant de les coller.

